

GUIDELINE ON LIQUEFIED NATURAL GAS STORAGE SYSTEM SAFETY

GAS SUPPLY ACT 1993

[Act 501]

**GUIDELINES ON LIQUEFIED NATURAL GAS
STORAGE SYSTEM SAFETY**

GP/ST/No.61/2026

IN exercise of the powers conferred by section 37C of the Gas Supply Act 1993 [Act 501], the Commission issues the following guidelines:

Citation and commencement

1. These guidelines may be cited as the Guidelines on Liquefied Natural Gas Storage System Safety.
2. These Guidelines shall come into operation on the date of the registration of these Guidelines.

Purpose

3. The purpose of these Guidelines are to establish the requirements for the installation and maintenance of the Liquefied Natural Gas (LNG) Storage System at commercial and residential premises.

Dated: 11 February 2026



SITI SAFINAH BINTI SALLEH
Chief Executive Officer
Energy Commission

TABLE OF CONTENTS

Chapter	Title	Page
1.0	Objectives	6
2.0	Application	7
3.0	Interpretation	7
	Regulatory Requirements	10
4.0	4.1 Design Approvals and Licenses	10
	4.2 Obligation of competent person and responsible person	10
	4.3 Compliance to Other Written Law	11
	Design and Technical Requirements	12
5.0	5.1 Pre-Requisites	12
	5.2 LNG Storage Specification	12
	5.3 Storage Capacity	13
	5.4 LNG Storage Installation	13
	5.5 Minimum Safety Distances	14
	5.6 Interconnecting Piping	15
	5.7 Ambient Vaporizers	17
	5.8 Odorization System	18
	5.9 Measuring Instrumentation	18
	5.10 Gas Leak Detector	19
	5.11 ESD	19
	5.12 Metering	20
	5.13 Safety Signs and Notices	20
6.0	Maintenance Requirements	21
7.0	Personal Protective Equipment (PPE) and Hand Tools	22
8.0	Relevant Standard Application	23

LIST OF TABLES

No.	Title	Page
Table 1	Design consideration for LNG Storage	12
Table 2	Minimum safety distances for LNG Storage Installation	14
Table 3	Proposed materials for interconnecting piping	17

APPENDICES

Appendix	Title	Page
A	Standard Safety Signage	25
B	Figure 1 - Minimum requirement for General Arrangement of LNG Cylinder Manifold System (Front view)	26
	Figure 2 - Minimum requirement for General Arrangement of LNG Cylinder Manifold System (Top view)	27
	Figure 3 - Minimum requirement for General Arrangement of LNG Microbulk (Stationary) System (Front view)	28
	Figure 4 - Minimum requirement for General Arrangement of LNG Microbulk (Stationary) System (Top view)	29
	Figure 5 - Minimum requirement for General Arrangement of LNG Bulk Tank System (Front view)	30
	Figure 6 - Minimum requirement for General Arrangement of LNG Bulk Tank System (Top view)	31

1.0 OBJECTIVES

These Guidelines are issued by the Commission for the following objectives:

- (a) to ensure that the storage of Liquefied Natural Gas (LNG) at commercial or residential premises comply with the requirements stipulated in the Act and the subsidiary legislations made under it and any relevant standard;
- (b) to be a reference for any person interested or involved in the construction of the LNG Storage System at commercial or residential premises in Peninsular Malaysia and Federal Territory of Labuan;
- (c) to facilitate the competent person in matters related to LNG Storage System;
- (d) to support the sustainability of the industry by enabling the use of an alternative fuel and providing new growth opportunities ~~to~~ aligned with the growing trend of adopting small-scale LNG solutions in Peninsular Malaysia and Federal Territory of Labuan;
- (e) to control and manage hazards arising from the installation of LNG storage system at commercial or residential premises; and
- (f) to promote the standardization of equipment specifications and installation for the LNG storage system and associated facilities.

2.0 APPLICATION

These Guidelines shall apply to—

- (a) the licensee;
- (b) the owner of the installation;
- (c) the competent person;
- (d) the Gas Contractor working on the installation; and
- (e) the assembler, manufacturer or importer of the gas fittings, equipment and accessories;

who are involved in the implementation, installation, operation and maintenance of the LNG storage system.

3.0 INTERPRETATION

3.1 In these Guidelines, unless the context requires, the definition of the terms are as follows:

Terms	Definition
Act	means the Gas Supply Act 1993 [Act 501];
ambient vaporizer	means a vaporizer that derives heat from naturally occurring heat sources, such as the surrounding atmosphere;
boundary	means the perimeter of the whole of the site under the same occupancy as the installation;
Bulk Storage Tanks	means the stationary cryogenic tank installations;
Commission	has the meaning assigned to it under the Act;
cryogenic tank	means the tank that is used to store LNG at -150 °C or lower;

deflection wall	means the wall, used to reduce the impact of explosions and fire. For two (2) hours fire resistance rating, it shall not be lower than two (2) metres high and shall be constructed from brickwork, masonry or concrete 100 mm thick or reinforced concrete 75 mm thick, or as specified in the latest version of MS830;
ESD	means an emergency shutdown system of controls and components that complies with specific requirements, which facilitates safe shutdown of gas in an emergency;
fire wall	means the wall used for the separation of adjoining buildings to prevent or reduce the spreading of fire from one building to another or from part of a building to another part of that building. For one (1) hour fire resistance rating, it shall be constructed from brickwork, masonry or concrete 100 mm thick or concrete 100 mm thick, or as specified in Uniform Building By-Laws 1984 (UBBL) or in any guidelines issued by Fire and Rescue Department of Malaysia (BOMBA);
competent person	has the same meaning assigned to it under the Act;
Gas Contractor	has the same meaning assigned to it under the Regulations;
gas leak detector	means a gas accessory specially designed to detect leaks in gas systems;
licensee	has the same meaning assigned to it under the Act;
Liquid Level Gauge	means a meter used to determine the liquid level in a process tank, vessel or drum;
LNG	means the liquefied natural gas under the Act;
LNG Storage System	means the system used to store LNG at the commercial or residential area;
MAWP	means the Maximum Allowable Working Pressure which refers to the maximum pressure to which a component or a system is designed to be subjected, and which is the basis for determining the strength of the component or system;

Microbulk Tanks	means the stationary cryogenic tank installations. They also can be designed to be transportable;
PTW	means Permit to Work which refers to the written permission to carry out specific works and which will specify how such works will be carried out as well as verify them;
PLC	means Portable Liquid Cylinders which refers to the cryogenic liquid cylinder is a specially designed vessel used to store and transport liquefied gases at extremely low temperatures, typically -150°C or below;
Pressure Gauge	means an instrument for measuring the condition of a fluid (liquid or gas) that is specified by the force that the fluid would exert, when at rest, on a unit area, such as pounds per square inch or newtons per square centimetre;
Regulations	means the Gas Supply Regulations 1997 [P.U.(A) 287/1997]
responsible person	has the same meaning assigned to it under the Regulations;
SS	means the stainless less which refers to a type of corrosion-resistant alloy of iron and chromium, often used in LNG installations for its strength and durability in extreme conditions.

3.2 Subject to paragraph 3.1 and unless expressly indicated to the contrary or unless the context otherwise requires, the terms adopted and used in these Guidelines shall bear the same meaning as they are defined in the Act and the subsidiary legislations made under it.

4.0 REGULATORY REQUIREMENTS

4.1 Design Approvals and Licenses

- (a) The owner of the LNG Storage System shall obtain—
 - (i) prior to the installation works, an Approval to Install (ATI) from the Commission; and
 - (ii) upon the completion of the installation, an Approval to Operate (ATO) from the Commission.

- (b) Any person shall apply and obtain a licence in accordance with section 11 of the Act for the purpose of supplying gas through the LNG Storage System.

- (c) Any licence granted in accordance with section 11B of the Act shall be displayed at any conspicuous place within the premises.

4.2 Obligation of Gas Contractor, competent person and responsible person

- (a) The Gas Contractor shall—
 - (i) be responsible for the design, installation and operation of the LNG Storage System; and
 - (ii) appoint a competent person to carry out or supervise the work in relation to the design, installation and operation of the LNG Storage System.

- (b) The competent person appointed by Gas Contractor shall—
 - (i) carries out or supervises the work in relation to the design, installation and operation of the LNG Storage System;
 - (ii) complies with any relevant regulatory and statutory requirements in Malaysia; and
 - (iii) complies with the manufacturer recommendations relating to the standard operation of the equipment.

- (c) A responsible person shall—
 - (i) be in charged of the LNG Storage System in the premises;
 - (ii) conduct regular inspections on the LNG Storage System; and
 - (iii) ensure that the LNG storage system is free from any gas leakage.

4.3 Compliance with other written law

The owner of LNG storage system, licensee, Gas Contractor and competent person shall—

- (a) ensure any installation and equipment used in the LNG Storage System is certified by the relevant authority in accordance with any applicable written law, regulations and industry standards; and

- (b) comply with any regulatory requirements issued by the relevant authority having jurisdiction.

5.0 DESIGN AND TECHNICAL REQUIREMENTS

5.1 Pre-Requisite

Prior to the application of ATI and ATO, the competent person appointed by the owner of the LNG Storage System or Gas Contractor shall—

- (a) ensure the compliance of Guidelines for Hazard Identification, Risk Assessment and Risk Control (HIRARC) and Major Hazard Control issued by the Department of Occupational Safety and Health Malaysia;
- (b) conduct facility siting and layout analysis for the purpose of installation of LNG Storage System; and
- (c) ensure the compliance with any requirements imposed by the relevant authority having jurisdiction.

5.2 LNG Storage Specification

Table 1 below illustrates the LNG storage capacity and design codes.

Storage	Recommended Design Code	Volume Capacity (L = litres)	MAWP (psig)
PLC	ISO 21029-1 or equivalent	175L to 1,000L	300
Microbulk Tanks	ASME BPVC or equivalent	230L to 3,000L	300
Bulk Storage Tanks	ASME BPVC or equivalent	3,000L to 100,000L	300

Table 1 - Design consideration for LNG storage

5.3 LNG Storage capacity

The aggregate water capacity of the LNG storage shall not exceed 100kL.

5.4 LNG Storage Installation

The following requirements shall be fulfilled by the Gas Contractor or the owner of the LNG Storage System, as the case may be:

- (a) The LNG storage shall—
 - (i) be installed on solid ground at outdoor location;
 - (ii) be readily accessible to LNG transport tanker;
 - (iii) not be located inside buildings, including basement;
 - (iv) not be located in an area where the safety of the public is or might be jeopardized; and
 - (v) not be used to store any unused LNG tank or PLC;

- (b) stationary cryogenic tanks shall be designed as either vertical or horizontal, securely bolted to a concrete foundation and installed above ground on solid ground level;

- (c) fencing shall be provided for the security or access control of LNG storage facilities. The fence shall—
 - (i) be constructed at minimum as a chain wire fence of strong and durable construction;
 - (ii) not be less than two (2) metres in height;
 - (iii) be located at least 1.5 metres from the nearest point of the container; and
 - (iv) be provided with both main and emergency gate, each lockable, outward-opening, and at least one (1) metre wide, located at opposite ends of the enclosure;

- (d) in the event where a fire wall is used as a boundary for the LNG storage area to reduce required the separation distance, it shall be constructed with a fire resistance rating of at least one (1) hour;
- (e) barriers or bollards poles shall be installed, where applicable, to prevent vehicular impact; and
- (f) the LNG storage system shall not be installed with any electrical wiring or equipment unless it is a certified explosion-proof type.

5.5 Minimum Safety Distances for LNG Storage Installation

- (a) For the purpose of the installation of LNG storage, the site location and internal equipment layout shall comply with the minimum safety distances as specified in Table 2 below:

Description	Minimum distance (metres)
Between LNG tanks	1.5
Boundary limit to LNG tank offloading connection	3.0
Boundary limit to outer shell of LNG tank: LNG storage tanks ≤ 100,000 litres	3.0
Fuelling vehicle to outer shell of LNG tank	4.0
Occupied buildings to LNG storage and other components containing LNG	15.0
Offloading connection to outer shell of LNG tank	6.0
On-site tank for flammable liquids and their gas vent to LNG tank offloading connection	5.0
On-site tank for flammable liquids and their gas vent to outer shell of LNG tank	5.0

Table 2 (Minimum safety distances of the installation of LNG storage)

- (b) Where the minimum safety distances cannot be met, a deflection wall shall be installed to achieve the required level of safety distances.

5.6 Interconnecting Piping

The interconnecting piping for the purpose of the LNG Storage System shall—

- (a) complies with the specifications as specified in Table 3;
- (b) be installed above ground. For this purpose, buried piping is not allowed within the LNG storage area;
- (c) be adequately supported to ensure it is securely fixed in its installed position. The support shall be capable to withstand the load of the piping and any vibration generated during gas distribution;
- (d) not have any item placed on it at any time;
- (e) ensure that all vent outlets—
 - (i) are piped to a common header;
 - (ii) are directed to a purpose-built vent stack for safe disposal; and
 - (iii) are positioned at a minimum height of six (6) metres above ground level or sufficiently higher than any nearby structures;
- (f) ensure that all types of connections (flanged and threaded)—
 - (i) are minimized to reduce potential leak sources; and
 - (ii) comply with ASME B31.3 or any equivalent recognized standard;

- (g) take into account thermal expansion and contraction shall be in the design of pipes exposed to cryogenic temperature. Thermal and fatigue stress shall be considered in pipe runs, with bends incorporated to mitigate thermal stress;
- (h) be equipped with thermal relief valves at the liquid and vapor section of the LNG Storage System where pressure may develop due to the vaporization of cryogenic liquid that is trapped in those section;
- (i) ensure that any changes in the direction of the piping use standard gas fittings. The use of non-standard gas fittings or manually welded parts is strictly prohibited;
- (j) ensure that all welding works is performed by a certified welder. Welding joints shall be minimized where practicable;
- (k) not be in contact with electrical cables or or any material which may generate sparks;
- (l) be equipped with electrical earthing and bonding systems having a resistance to earth of not more than ten (10) ohms; and
- (m) be protected by a lightning protection system for LNG storage as recommended by a risk assessment.

Scope of Pipework	Proposed Materials or equivalent standards
Ambient vaporizer	ASTM 6061 / 6063 or SS 304 / SS 316
Cryogenic hoses (for transfer of LNG)	SS 321
Cryogenic manual valves and ESVs (ESVs shall be designed as fire-safe, in accordance with ISO 14313)	SS 304
Valves, Regulators, Piping and Fittings	Valves - SS 304 Regulators - Brass / SS 304 Piping / fittings - SS 304
Piping between storage or PLC to inlet of the ambient vaporizer	SS 304, seamless pipe
Piping from valves/regulators/piping/fittings to the point of use	SS 304
Piping from outlet of the ambient vaporizers to the valves/regulators/piping/fittings	SS 304
Thermal relief valves	Brass / SS 304

Table 3 – Scope of pipework and proposed materials for interconnecting piping

5.7 Ambient Vaporizers

All ambient vaporizers shall—

- (a) be located in the area where air circulation is not restricted (refer to Table 2 for safety distance);
- (b) be designed for operation at a temperature of -162 °C or lower;
- (c) be anchored and the connecting piping shall be able to accommodate expansion and contraction during temperature change;
- (d) be equipped with a relief valve; and
- (e) consist of equipment and systems capable to:

- (i) monitoring and detecting low temperature, high flow rates of cold liquid, or loss of heat supply to the vaporizers; and
- (ii) performing safety interlock functions, including a safe shutdown system.

5.8 Odorization System

In the absence of an odorization system in a tank or PLC, the Gas Contractor shall ensure that the odorization system—

- (a) complies with regulation 55 of the Regulations in relation to gas concentration;
- (b) is installed in a well-ventilated area;
- (c) is capable of withstanding at least the MAWP of the LNG Storage System;
- (d) is fitted with a backflow check valve at the odorant outlet;
- (e) is equipped with devices that can trigger an emergency shutdown in the event of an actual loss of odorization; and
- (f) is installed, tested, and commissioned in accordance with the manufacturer's instructions and recommendations for Factory Acceptance Test (FAT) and Site Acceptance Test (SAT).

5.9 Measuring Instrumentation

The LNG storage system shall be equipped with the following measuring instruments:

- (a) Pressure Gauge
 - (i) each LNG storage shall be equipped with a pressure gauge; and
 - (ii) it should be fitted with two (2) independent pressure devices.
- (b) Liquid Level Gauge
 - (i) Each LNG storage shall be fitted with two (2) independently operated level measuring systems; and

- (ii) Each of the level measuring systems shall be capable of automatically stopping any offloading operation and closing the valve through which LNG is supplied to the storage.

5.10 Gas leak detector

The gas leak detector shall –

- (a) be designed and installed within the vicinity of all gas appliances, within a maximum distance of three (3) metres, taking into account the operating range and sensitivity of the gas leak detector, and the percentage of Lower and Upper Flammability Limit of LNG;
- (b) be connected to a safety alarm located in an area accessible to the public and linked to an automatic shut-off device; and
- (c) provide constant read-out either to a central monitoring location or to a local ESD.

5.11 ESD

- (a) The ESD shall be activated by the following:
 - (i) detection of gas leaks by gas leak detectors;
 - (ii) failure of main power supply or instrument power; and
 - (iii) manual activation of any ESD push button.
- (b) Upon activation of the ESD—
 - (i) a local alarm with both audible and visual signals shall be activated; and
 - (ii) the LNG fuelling station operating company shall be automatically notified through an alarm, electronic communication or other similarly effective means.

- (c) ESD equipment shall only be reset manually by the designated responsible person.

5.12 Metering

- a) In the event of the LNG installation is intended for retail activity, all metering system shall be in accordance with regulation 78, regulation 79, regulation 80 and regulation 136 of the Regulations.
- b) Gas meter shall:
 - (i) be located in ventilated space, readily accessible locations for inspection, reading, replacement and maintenance;
 - (ii) be located at least 0.9 m away from any ignition source;
 - (iii) not be located in areas exposed to physical damage, corrosion, vibration or obstruction;
 - (iv) not be located in area subject to extreme temperatures or conditions exceeding the manufacturer's specification; and
 - (v) be covered and provided at least with Ingress Protection 54 for outdoor installation.

5.13 Safety Signs and Notices

A safety briefing shall be conducted by the licensee or responsible person or a competent person before individual enters the LNG storage area. Signs shall be displayed at conspicuous locations to indicate the following:

- (a) prohibited access to non-public areas by an unauthorized person;
- (b) the presence of hazardous areas;
- (c) flammable liquid and gas;
- (d) low temperature (cryogenic) liquid;
- (e) prohibition of smoking, open fire, and the use of non-explosion protected electric or electronic equipment including personal electronic devices (e.g. cameras, mobile phones, computers, radios, etc.); and

- (f) for premises operating on a 24-hours basis, the contact number of the responsible person and other emergency contacts (e.g. police, fire department) shall be displayed in areas commonly frequented by the public.

6.0 MAINTENANCE REQUIREMENTS

- (a) A PTW shall be issued by the licensee, authorizing the competent person to carry out maintenance works.
- (b) The responsible person shall perform the maintenance of the LNG Storage System in accordance with the requirements of the Act and the Regulations. In the absence of the applicable guidelines or standards for gas fitting, equipment or accessories, the maintenance activities shall be carried out in accordance with manufacturer instructions and recommendations.
- (c) Inspection and maintenance records must be verified by a competent person, and retained by the responsible person for reference and audit purposes.

7.0 PERSONAL PROTECTIVE EQUIPMENT (PPE) AND HAND TOOLS

The following requirements shall be fulfilled and provided by the Gas Contractor or the licensee of the LNG Storage System during handling and maintenance work. The PPE shall include but not limited to the following:

- (a)* full-face shields;
- (b)* safety helmet;
- (c)* non-sparking tools;
- (d)* cryogenic hand gloves;
- (e)* high-cut type safety shoes;
- (f)* ears protection;
- (g)* portable gas leak detector;
- (h)* flame-retardant clothing (top and bottom);
- (i)* flame-resistance reflective vest; and
- (j)* cryogenic apron.

8.0 RELEVANT STANDARDS APPLICATION

STANDARDS	DETAILS DESCRIPTION
ACI 376	Code Requirements for Design and Construction of Concrete Structures for The Containment of Refrigerated Liquefied Gases
API 510	Pressure Vessel Inspector
API RP 572	Inspection Of Pressure Vessels
AS 3961:2017	The Storage and Handling of Liquefied Natural Gas
ASME B31.3 - 2022	ASME Process Piping
ASME B31.4 - 2022	Pipeline Transportation Systems for Liquids and Slurries
ASME B31.8 - 2022	ASME Gas Transmission and Distribution Piping Systems
ASME BPVC	ASME Boiler and Pressure Vessel Code (BPVC)
BS EN 13458-1:2002	Cryogenic Vessels. Static Vacuum Insulated Vessels. Fundamental Requirements (British Standard)
BS EN 13458-2	Cryogenic Vessels. Static Vacuum Insulated Vessels Design, Fabrication, Inspection and Testing
CGA 341-2007	ANSI Specification for Insulated Cargo Tank for Non-flammable Cryogenic Liquids
CSA Z276	Liquefied Natural Gas (LNG) – Production, Storage and Handling
CSN EN 1473	Installation And Equipment for Liquefied Natural Gas – Design of Onshore Installations
CSN EN14620-1, CSN EN14620-2	Design and Manufacture of Site Build, Vertical, Cylindrical, Flatbottomed Steel Tanks for The Storage of Refrigerated, Liquefied Gases With Operating Temp Between 0c And -165c
EN 13445	Unfired Pressure Vessels
EN 1445 + PED 2014/68/EU	Pressure Equipment Directive
EN10025-2:S3 55J2 and 5235J2	Hot Rolled Product of Structural Steels

EN10028-7:SS 304/304L	Chemical Composition of Stainless-Steel Flat Product for Pressure Purpose to BS EN 10028-7
IGEM/TSP/18/036	Institution Of Gas Engineers and Managers (IGEM) - Liquefied Natural Gas Fuelling Stations
ISO 16924:2016	Natural Gas Fuelling Stations — LNG Stations For Fuelling Vehicles
ISO 21029-1	Cryogenic vessels — Transportable vacuum insulated vessels of not more than 1 000 litres volume
MS830:2021	Code Of Practice for The Storage, Handling and Transportation of Liquefied Petroleum Gases.
MS930:2017	Installation Of Dual Gas Piping Systems and Appliances - Code of Practice (Second Revision)
NFPA 59A:2023	NFPA 59A, Standard for The Production, Storage, And Handling of Liquefied Natural Gas (LNG) (2023)
PED 2014/68/EU	Pressure Equipment Directive
TR74: 2020	Code Of Practice for Storage, Land Transportation and Handling Of LNG

APPENDIX A

Standard Safety Signage

(geometric shapes and sizes shall be as per latest version of MS830)

SIGN	MEANING
	Smoking is Prohibited
	Fire, naked light and smoking are prohibited
	Nearby material is a fire risk
	No handphone

APPENDIX B
LIST OF FIGURES

MINIMUM REQUIREMENT FOR GENERAL ARRANGEMENT OF LNG STORAGE SYSTEM

(for illustration only - not drawn to scale – all measurements in mm)

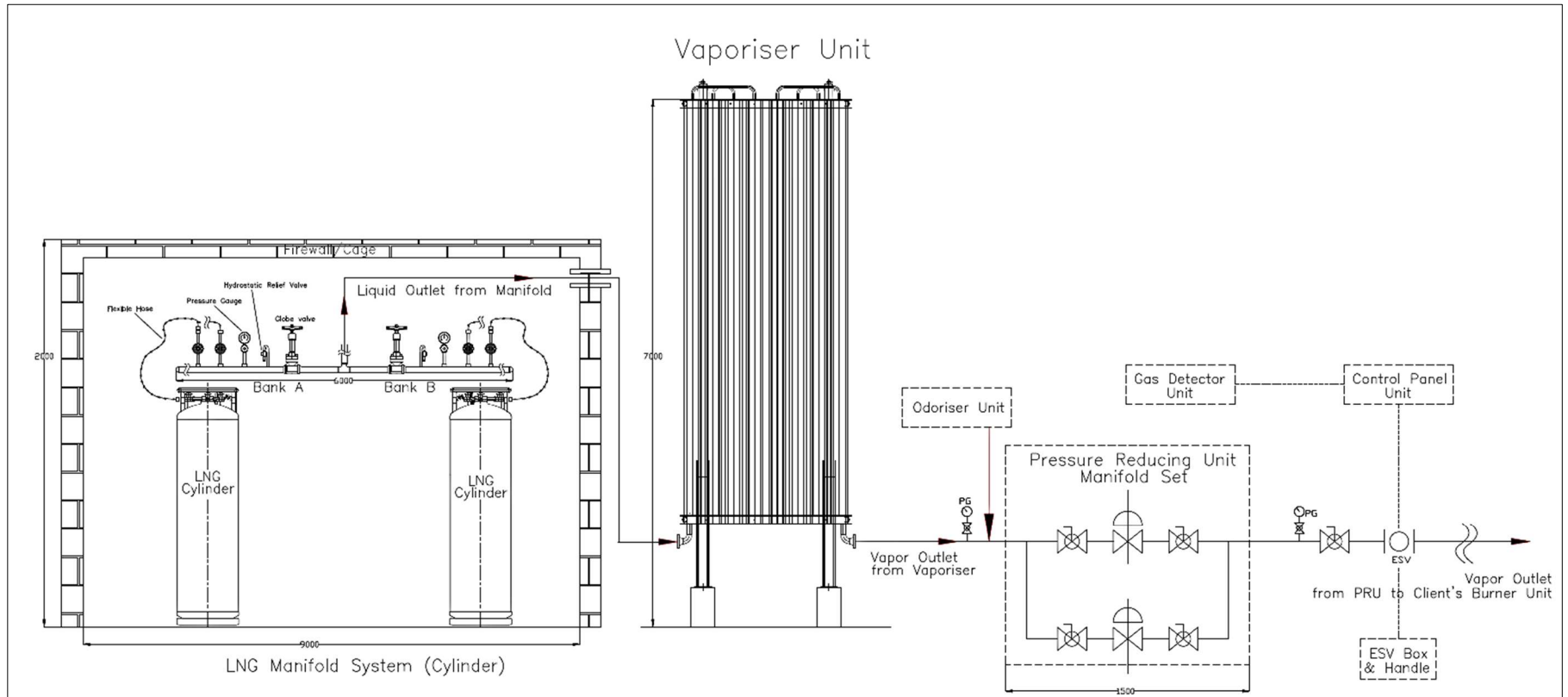

Figure 1: Minimum requirement for general arrangement of an LNG cylinder manifold system (front view)

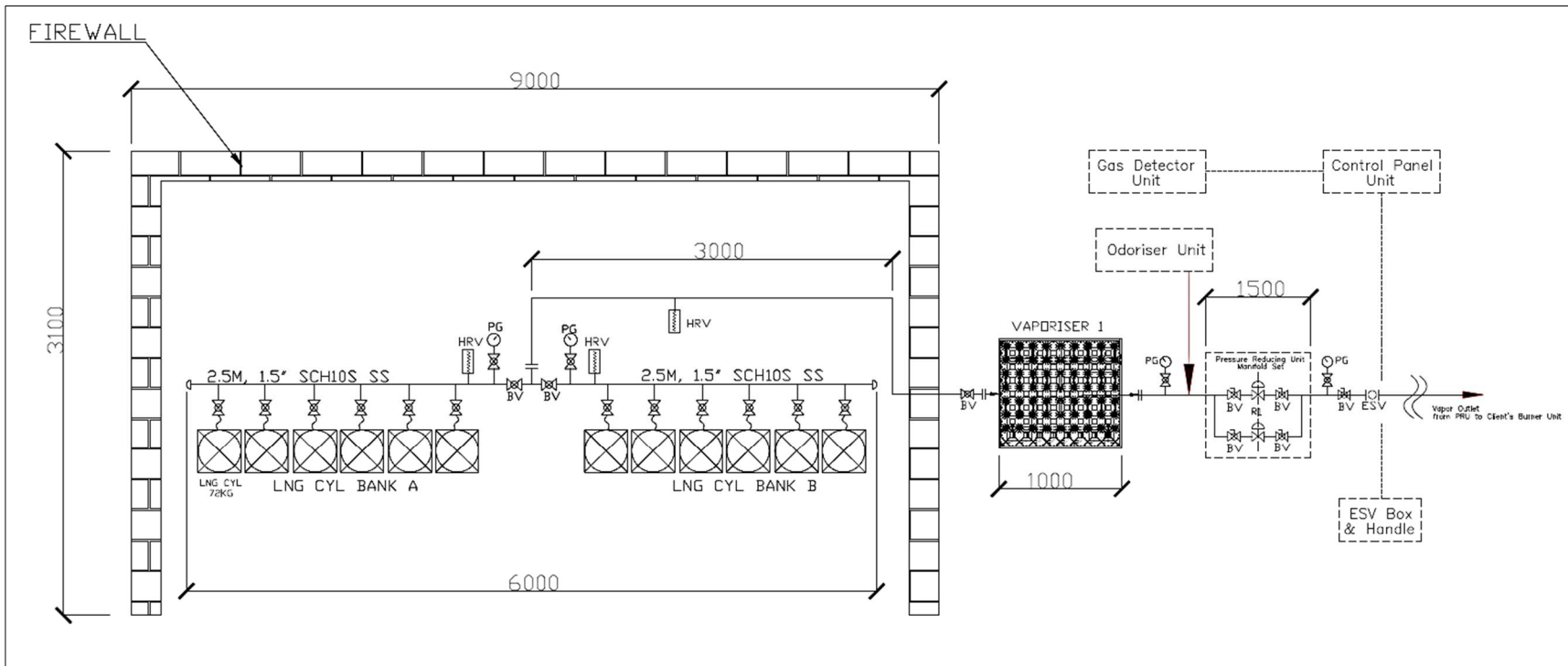

Figure 2: Minimum requirement for general arrangement of an LNG Cylinder Manifold System (top view)

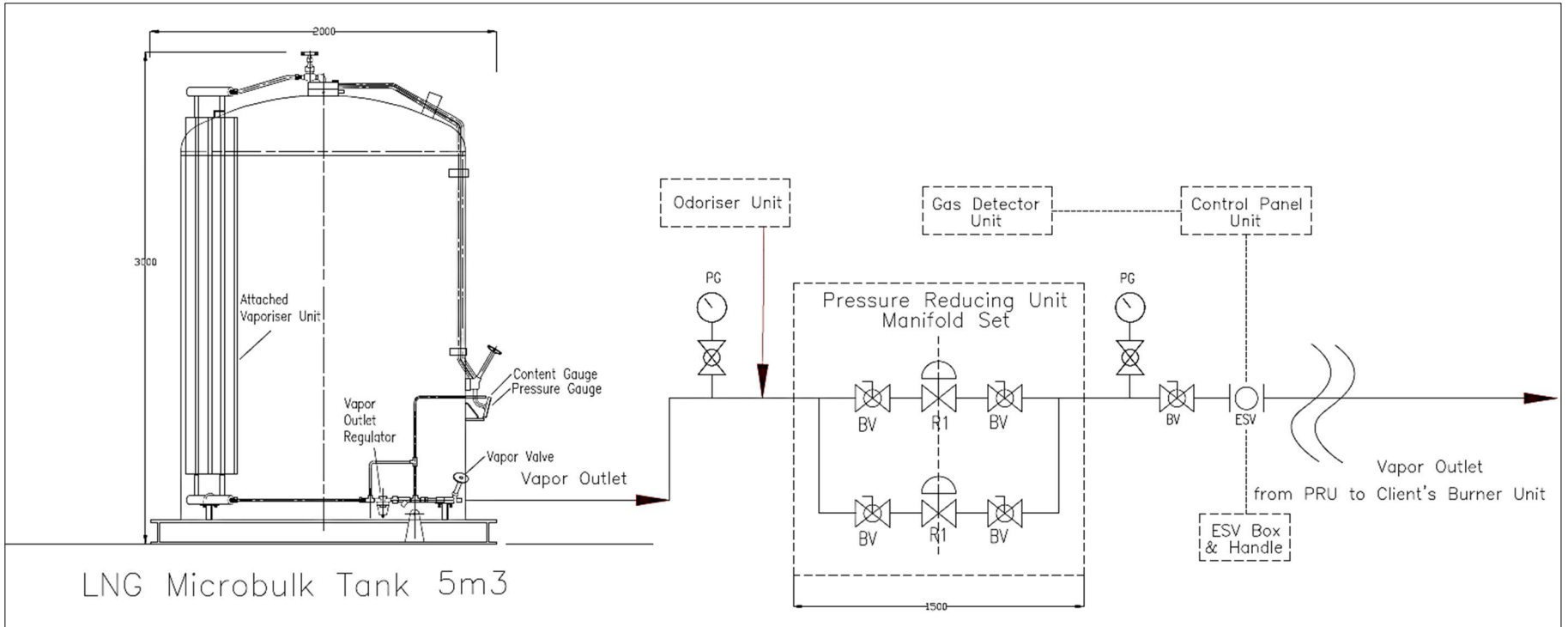

Figure 3: Minimum requirement for general arrangement of an LNG Microbulk System (front view)

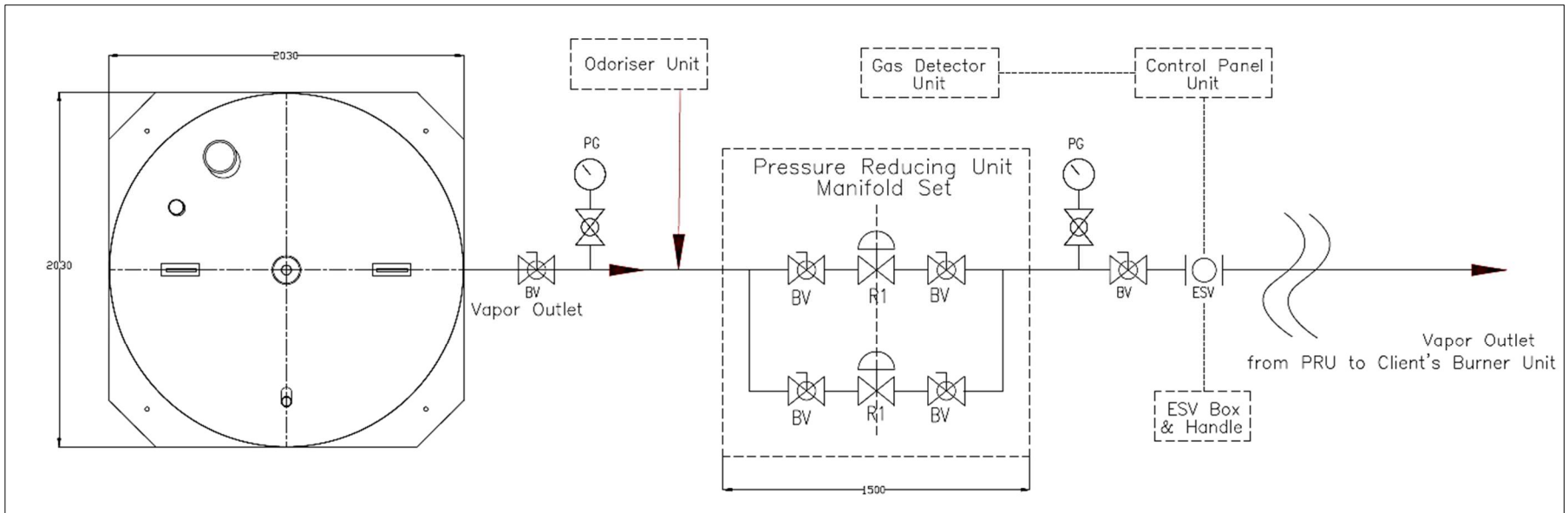

Figure 4: Minimum requirement for general arrangement of an LNG Microbulk System (top view)

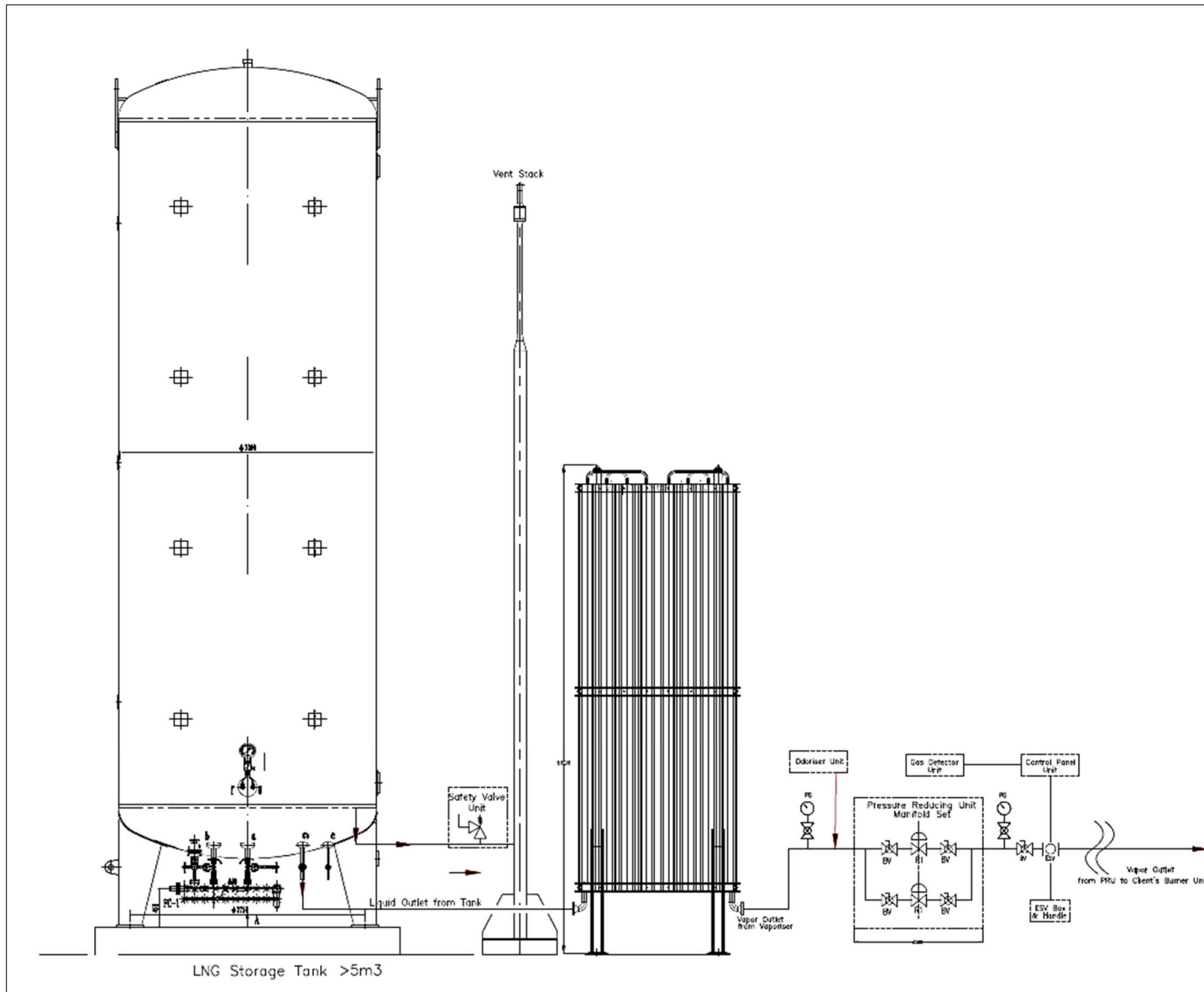

Figure 5: Minimum requirement for general arrangement of an LNG Bulk Tank System (front view)

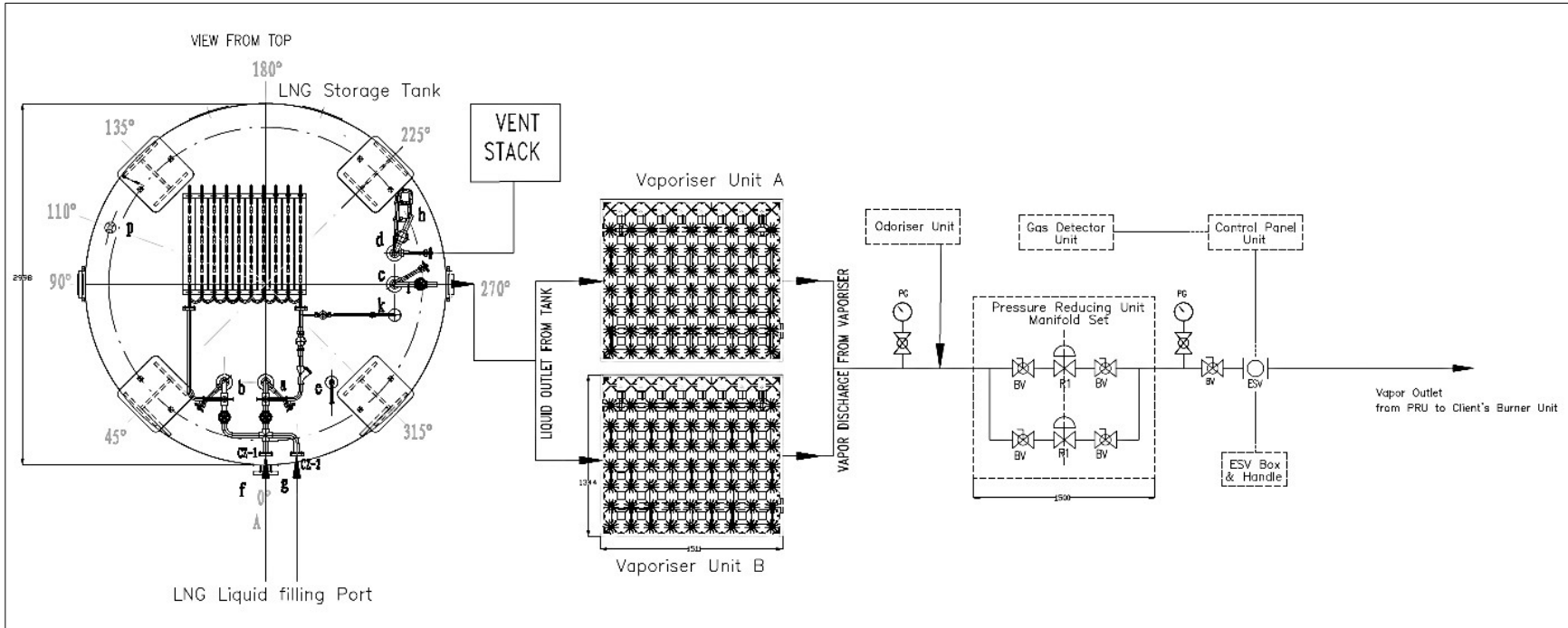

Figure 6: Minimum requirement for general arrangement of an LNG Bulk Tank System (top view)



SURUHANJAYA TENAGA (ENERGY COMMISSION)

NO. 12, JALAN TUN HUSSEIN, PRECINCT 2,
62100 PUTRAJAYA



(603) 8870 8500



www.st.gov.my